

## HENRY

HNHS10

Henry Handshower On Bar



SHOWN IN HENRY HANDSHOWER ON BAR | HNHS10

### TECHNICAL DETAILS

ADA Compliance: Yes  
 Adjustable Versus Fixed Spray: Fixed Spray  
 Depth/Width: 4 9/16"  
 Escutcheon Primary Material: Brass  
 Fittings Hole Diameter: 1 1/4"  
 Flow Restriction Options: 2.5, 2.2, 2.0, 1.75, 1.5, 0.92  
 Handshower Spray Hose Length: 59"  
 Height: 24"  
 Inlet Connection Size: 1/2"  
 Inlet Connection Type: Female NPT  
 Integrated Diverter: N  
 Pivot: Y  
 Primary Material: Brass  
 Suggested Application: Bath  
 Water Pressure Maximum: 85.0 psi  
 Water Pressure Minimum: 20.0 psi  
 Water Pressure Recommended: 45.0 psi

### INSPIRATION

Influenced by the connection of industry and art Henry easily transitions between modern, traditional, utilitarian and classic settings.

### CODES & STANDARDS

ASME A112.18.1/CSA B125.1, Waterworks Handshowers use check valves compliant to ASME A112.18.3 for backflow protection. CEC, State of MA

### PRODUCT FEATURES

Brass material is used for components

Features a supply elbow with integrated hook to hold the handshower.

This handshower offers a refine or compact look in the shower.

Stocked in 2.5gpm (9.5 L/min) and 1.75gpm (6.6 L/min). State of California requires 1.75gpm (6.6 L/min) to comply with their water conservation requirements. Other flow options are available to order, contact your sales associate or call 1 (800) 899-6757 for details

### CERTIFICATIONS



### PRODUCT (NOTES)

# WATERWORKS

## HENRY

Henry Handshower On Bar

HNHS10

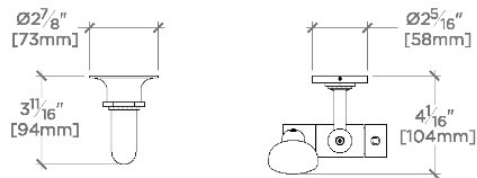

TOP VIEW

SCALE: 1 1/2"=1'-0"

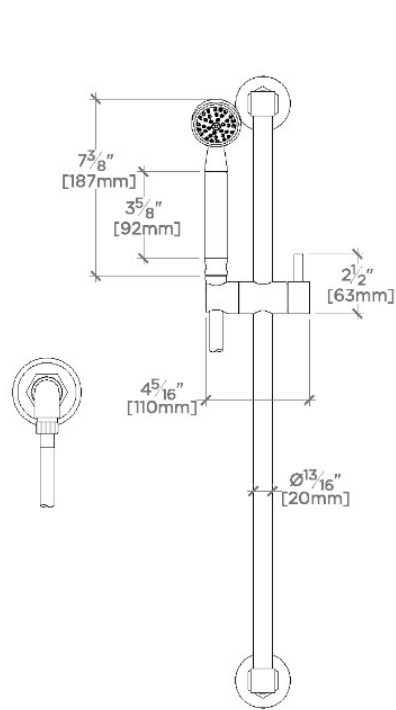

FRONT VIEW

SCALE: 1 1/2"=1'-0"

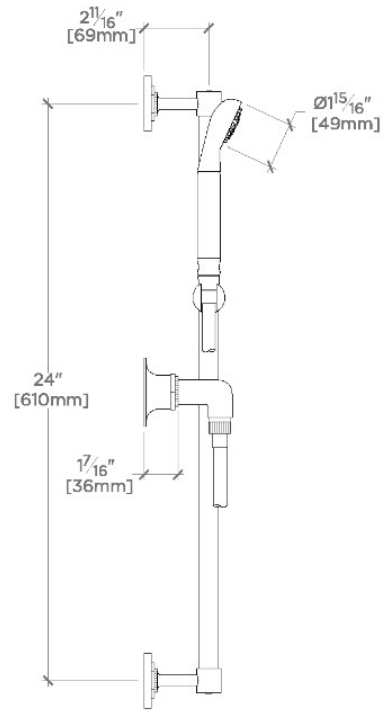

SIDE VIEW

SCALE: 1 1/2"=1'-0"